



BaerFix® Thread Inserts - Construction

Calculation for minimum values

d = internal diameter BaerFix insert

D = external diameter BaerFix insert

R = remaining wall thickness

$$R_{\min}(\text{light alloys}) = 0,2 \times D$$

$$R_{\min}(\text{cast iron}) = 0,3 \times D$$

$$R_{\min}(\text{plastics}) = 0,25 \times D$$

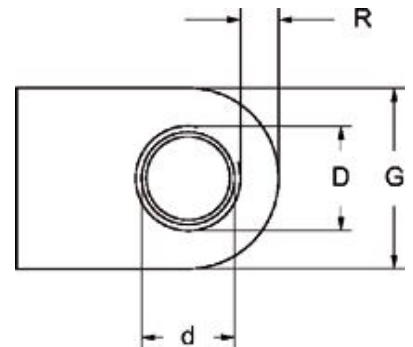

	BaerFix® Thread Inserts with cutting slots			BaerFix® Thread Inserts with cutting holes		
	light alloys	cast iron	plastics	light alloys	cast iron	plastics
M 2 x 0,4	0,90 mm	1,35 mm	1,13 mm			
M 2,5 x 0,45	0,90 mm	1,35 mm	1,13 mm			
M 3 x 0,5	1,00 mm	1,50 mm	1,25 mm	1,00 mm	1,50 mm	1,25 mm
M 4 x 0,7	1,30 mm	1,95 mm	1,63 mm	1,30 mm	1,95 mm	1,63 mm
M 5 x 0,8	1,60 mm	2,40 mm	2,00 mm	1,60 mm	2,40 mm	2,00 mm
M 6 x 1	2,00 mm	3,00 mm	2,50 mm	2,00 mm	3,00 mm	2,50 mm
M 8 x 1,25	2,40 mm	3,60 mm	3,00 mm	2,40 mm	3,60 mm	3,00 mm
M 10 x 1,5	2,80 mm	4,20 mm	3,50 mm			
M 12 x 1,75	3,20 mm	4,80 mm	4,00 mm			
M 14 x 2	3,60 mm	5,40 mm	4,50 mm			
M 16 x 2	4,00 mm	6,00 mm	5,00 mm			
M 18 x 2,5	4,40 mm	6,60 mm	5,50 mm			
M 20 x 2,5	5,20 mm	7,80 mm	6,50 mm			
M 22 x 2,5	5,20 mm	7,80 mm	6,50 mm			
M 24 x 3	6,00 mm	9,00 mm	7,50 mm			
M 27 x 3	6,80 mm	10,20 mm	8,50 mm			
M 30 x 3,5	7,20 mm	10,80 mm	9,00 mm			

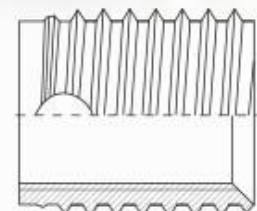
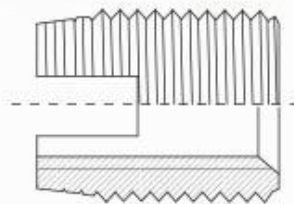

minimum borehole depth

BaerFix® Thread Inserts

BaerFix® Thread Inserts

	with cutting slots	
internal thread	min. bohrhole depth for through holes	min. bohrhole depth for blind holes
M 2 x 0,4	6,00 mm	8,00 mm
M 2,5 x 0,45	6,00 mm	8,00 mm
M 3 x 0,5	6,00 mm	8,00 mm
M 4 x 0,7	8,00 mm	10,00 mm
M 5 x 0,8	10,00 mm	13,00 mm
M 6 x 1	14,00 mm	17,00 mm
M 8 x 1,25	15,00 mm	18,00 mm
M 10 x 1,5	18,00 mm	22,00 mm
M 12 x 1,75	22,00 mm	26,00 mm
M 14 x 2	24,00 mm	28,00 mm
M 16 x 2	22,00 mm	27,00 mm
M 18 x 2,5	24,00 mm	29,00 mm
M 20 x 2,5	27,00 mm	32,00 mm
M 22 x 2,5	30,00 mm	36,00 mm
M 24 x 3	30,00 mm	36,00 mm
M 27 x 3	30,00 mm	36,00 mm
M 30 x 3,5	40,00 mm	46,00 mm

	with cutting slots	
internal thread	min. bohrhole depth for through holes	min. bohrhole depth for blind holes
UNC 4 x 40	6,00 mm	8,00 mm
UNC 6 x 32	8,00 mm	10,00 mm
UNC 8 x 32	8,00 mm	10,00 mm
UNC 10 x 24	10,00 mm	13,00 mm
UNC 1/4 x 20	14,00 mm	17,00 mm
UNC 5/16 x 18	15,00 mm	18,00 mm
UNC 3/8 x 16	18,00 mm	22,00 mm
UNC 7/16 x 14	22,00 mm	26,00 mm
UNC 1/2 x 13	22,00 mm	28,00 mm
UNC 5/8 x 11	22,00 mm	27,00 mm

	BaerFix® Thread Inserts with cutting holes	
internal thread	min. bohrhole depth for through holes	min. bohrhole depth for blind holes
M 3 x 0,5	4,00 mm	6,00 mm
M 4 x 0,7	6,00 mm	8,00 mm
M 5 x 0,8	7,00 mm	9,00 mm
M 6 x 1	8,00 mm	10,00 mm
M 8 x 1,25	9,00 mm	11,00 mm

	BaerFix® Thread Inserts with cutting slots	
internal thread	min. bohrhole depth for through holes	min. bohrhole depth for blind holes
UNF 4 x 48	6,00 mm	8,00 mm
UNF 6 x 40	8,00 mm	10,00 mm
UNF 8 x 36	8,00 mm	10,00 mm
UNF 10 x 32	10,00 mm	13,00 mm
UNF 1/4 x 28	14,00 mm	17,00 mm
UNF 5/16 x 24	15,00 mm	18,00 mm
UNF 3/8 x 24	18,00 mm	22,00 mm
UNF 7/16 x 20	22,00 mm	26,00 mm
UNF 1/2 x 20	22,00 mm	28,00 mm
UNF 5/8 x 18	22,00 mm	27,00 mm